

One Year Unconditional Warranty

If for any reason, this ProMaster product fails within ONE YEAR of the date of purchase, return this product to your ProMaster dealer and it will be exchanged for you at no charge. ProMaster products are guaranteed for ONE FULL YEAR against defects in workmanship and materials. If at any time after one year, your ProMaster product fails under normal use, we invite you to return it to ProMaster for evaluation.

WWW.PROMASTER.COM | FAIRFIELD CT 06825

**FOR
SONY**

Made in China
Code 8469



1705L [Speedlight]

TTL Speedlight for Sony

1705L SPEEDLIGHT FOR SONY



Contents

Foreword	2
Precautions	3
Parts Identification	4
LCD Panel Icons	6
Inserting the Batteries	7
Attaching and Detaching	8
Turning on the Power	9
Sound Monitor and Key Lock	10
TTL (Auto) Mode	11
M (Manual) Mode	12
MULTI (Multiple Flash) Mode	13
Master Mode (WL CTRL ⁺)	15
Master Mode (WL CTRL ⁺ RATIO)	17
Slave Mode (WL TTL RMT)	20
Slave Mode (WL TTL RMT 2)	21
Slave Mode (WL M RMT)	22
Slave Mode (WL M RMT 2)	23
Slave Mode F1 (Optical)	24
Slave Mode F2 (Optical)	25
Using the Camera's Built-in Flash as a Master (CTRL ⁺)	26
Power Zoom Function	27
AF Assist Beam Emitter (AF)	28
Bounce Flash Operation	29
Using the Bounce Card	30
Using the Wide Panel	31
Additional Interfaces	32
Appendix	33
Specifications	34

Foreword

Thank you for purchasing the [pro]master 170SL.

The ProMaster 170SL is a high performance Sony TTL/ADI compatible flash unit with a guide number of 52 m/170 ft (ISO 100 at the 180mm zoom position). The 170SL works with your camera as a TTL/ADI auto flash or as a manual control unit. It can serve as an on-camera flash as well as a master unit or a slave unit in a wireless, multiple-speedlight system.

Here are some of the 170SL's features:

- High Guide number: 52
- Low Recycle time: 4.5 seconds (AA alkaline) or 2.5 seconds (AA NiMH rechargeable)
- 22 Levels of light output control
- Compatible with the Sony wireless, optical flash system (can be used as master or slave)
- Compatible with the Sony TTL/ADI autoflash system
- Power zoom function matches your lens focal length
- Supports front-curtain/rear-curtain sync
- Thermal cut-off protection to prevent overheating

To get the most out of your speedlight, please read this manual thoroughly before use.

Included items

Your 170SL comes with the following accessories.

- Soft Storage Case
- User's manual
- Speedlight Mini Stand

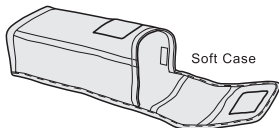
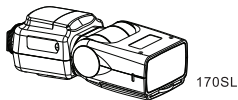

Mounting Foot Cover



Mini Stand

Precautions

1. Do not disassemble, open, or repair this speedlight by yourself.
2. Always use batteries of the same type, brand, and age. Always replace all 4 batteries at the same time. Do not combine different types, brands, old, or new batteries. This could cause the batteries to overheat, leak, or explode.
3. This product is not water-resistant. Keep it away from rain, snow, and high humidity areas.
4. Install the batteries in proper orientation as indicated in the battery chamber. Installing the batteries incorrectly could cause them to overheat, leak, or explode.
5. If you change the batteries after a period of sustained continuous firing of the speedlight, the batteries may become warm or hot. This is normal, however you should be careful when handling these batteries.
6. Always switch the speedlight off before changing batteries.
7. Do not fire the speedlight from a short distance directly into the eyes of people or animals. This can cause damage to the retina and may even lead to blindness.
8. Avoid corrosive or flammable substances when cleaning this speedlight.
9. To prevent overheating and damage to the flash head, do not fire more than 25 continuous flashes in rapid sequence at full power (1/1 level). In this case the overheating mode will be activated and the flash will shut down. Allow it to return to normal operating temperature before using. This takes about 15 minutes.
10. Do not touch the speedlight with wet hands. This could cause an electrical shock.
11. Remove batteries from the unit before storing.

Parts Identification

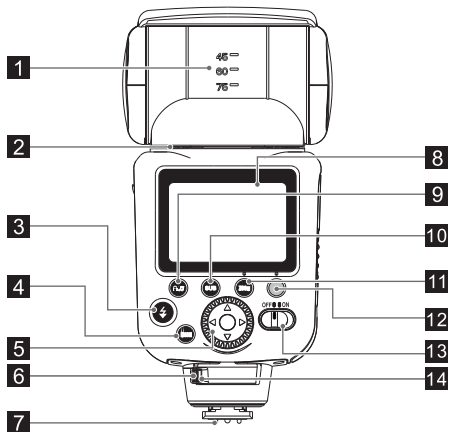

- | | |
|--|---|
| 1 Tilting angle scale | 9 Key lock/Sound button |
| 2 Rotating angle scale | 10 SUB button/
Master mode button |
| 3 Test firing button | 11 Zoom button |
| 4 Flash mode button/
Slave mode button | 12 Charging indicator
(ready light) |
| 5 Navigation panel | 13 Power switch
(OFF/ON) |
| 6 Lock-release button | 14 Mounting foot's
locking lever |
| 7 Contact foot | |
| 8 LCD panel | |

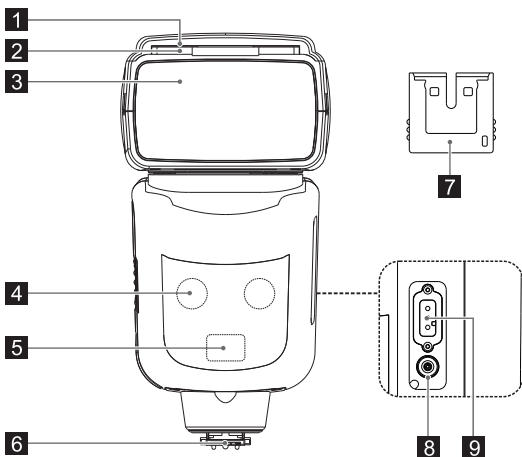

Parts Identification









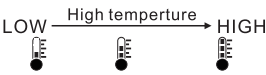

- 1** Bounce card
- 2** Built-in widepanel
- 3** Flash head
- 4** AF-assist beam emitter
- 5** Optic control sensor

- 6** Connect pins
- 7** Connector protect cap
- 8** PC terminal
- 9** External power source socket (H.V. port)

LCD Panel Icons

	Wireless Master Icon
	Wireless Slave Icon
	Wireless mode indicator (WL/Remote)
AF	AF-assist beam emitter
RATIO	Lighting ratio control
CTRL ⁺	Master mode
RMT	WL RMT (Remote 1)
RMT2	WL RMT2 (Remote 2)
Hz	Frequency(MULTI)
TIMES	Flash times(MULTI)

	
	Sound on
	Batteries low power
	Camera communication
	Channel
	Standby/Sleep
	Key lock
	Manual zoom
	Auto zoom



If the temperature of the unit becomes too high, this icon  will appear in the LCD screen. You will hear short beeps for 15 seconds as the unit locks-up for thermal protection. Please turn off the speedlight for 10 minutes until it cools down.

Basic Operation

■ Inserting the Batteries

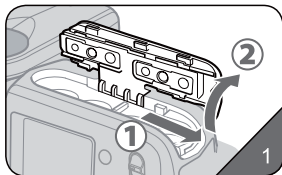

❶ Open the cover.

Slide cover in the direction of the arrow and flip open.

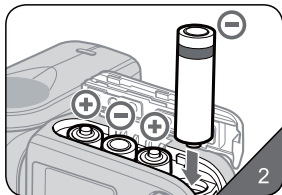

❷ Install the batteries.

Make sure the + and - battery contacts are properly oriented as shown inside the battery compartment.

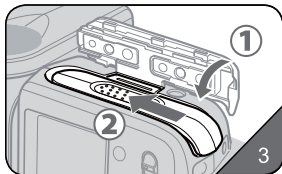

❸ Close the cover.

Close the battery compartment cover by flipping it down, pressing, and sliding it closed.

- Only use size AA alkaline or Ni-MH batteries.
- If you change the batteries after firing many continuous flashes, be aware that the batteries might be hot.
- Before changing the batteries, be sure to turn off the speedlight.
- When you change the batteries, be sure to use the same type and with full power.
- Remove the batteries from the speedlight before storing.

Basic Operation

Attaching and Detaching

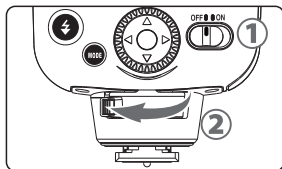

1 Prepare to attach the Speedlight

Slide the cover to the left. If the lever is in the locked position (to the right) push the button to unlock it before sliding left.

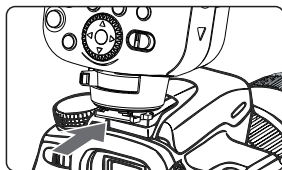

2 Attaching the speedlight

Mount the speedlight into the camera's hot shoe all the way.

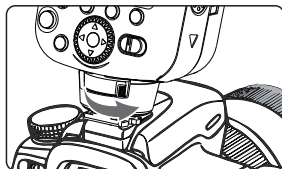

3 Securing the speedlight

On the mounting foot, slide the lock lever to the right until it locks into place.

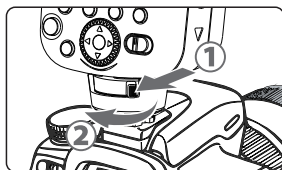

4 Detaching the speedlight

While pressing the lock-release button, slide the lock lever to the left and detach the speedlight by sliding it out of the camera's shoe.

- Before attaching or detaching the speedlight, be sure to turn off the speedlight.

Basic Operation

■ Turning On The Power

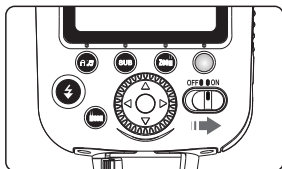

① Turn on the power

- Slide the power switch to <ON>. The charging indicator light will begin as red, then change to green after a few seconds, and you will hear two beeps. The speedlight is now ready.

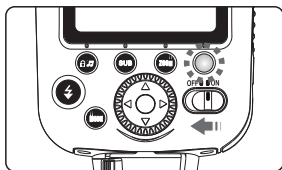

② Turn off the power

- Slide the power switch to <OFF>.

- If the charging indicator remains red, and the low power icon is displayed, please replace the batteries with new ones.
- In order to conserve power, the speedlight will enter sleep mode after 3 minutes of no use. In sleep mode the LCD will go blank. You can press the camera's shutter button halfway or press the test fire button to wake it up.
- The 170SL will NOT enter sleep while in Slave Mode.

Basic Operation

Sound Monitor

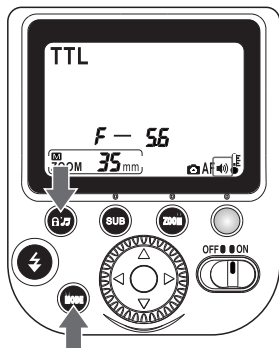

Enable sound monitor



Press the <SOUND>button



The sound icon will blink



Press <MODE> to confirm

Disable sound monitor



Press the <SOUND>button



The sound icon will blink



Press <MODE> to confirm

Key lock

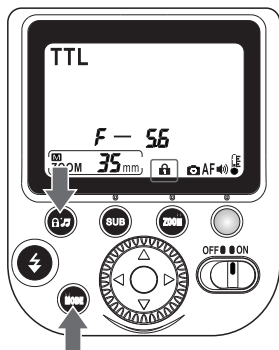

Enable key lock



Press the <KEY LOCK> button once



The sound icon will blink



Press the <KEY LOCK> button a second time



Now the key lock icon will blink



Press <MODE> button to confirm

Disable key lock



Press and hold the <KEY LOCK> button for 2 seconds until the key lock icon disappears

Flash Modes

TTL(Auto) Mode

In this mode information obtained by monitor pre-flashes and exposure control information are combined in-camera to automatically adjust flash output levels.

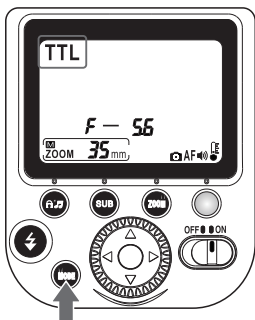

1 Set the 170SL to <TTL> mode

Press the <MODE> button until <TTL> appears on the LCD screen. Each time you press this button the 170SL will toggle among TTL, M, and MULTI modes. Watch the upper, left corner of the screen.

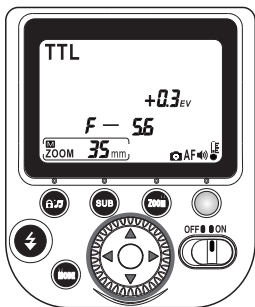

2 Set the flash exposure compensation

Press the left/right arrows on the navigation panel to decrease/increase the flash exposure compensation by whole EV stops.

3 Fine tuning the flash exposure compensation

Press the up/down arrows on the navigation panel to increase/decrease the flash exposure compensation by 1/3 EV stops.

- When using a Sony camera and fully compatible lens, the 170SL's exposure and focal length are automatically set to match the camera settings unless you change them.

Flash Modes

M (Manual) Mode

You can set the speedlight to manual mode and choose a power level between 1/1 and 1/128 in 1/3 step increments.

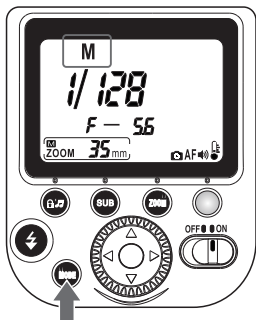

1 Set the speedlight to <M> mode

Press the <MODE> button until <M> appears on the LCD screen. Each time you press this button the 170SL will toggle among TTL, M, and MULTI modes. Watch the upper, left corner of the screen.

TTL → M → MULTI

2 Set the flash power

Press the left/right arrows on the navigation panel to decrease/increase the flash output level by whole EV stops.

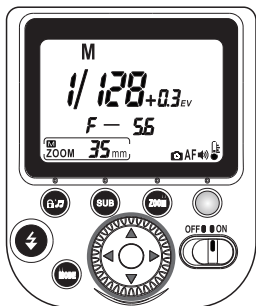

3 Fine tuning the flash power

Press the up/down arrows on the navigation panel to decrease/increase the flash output level by 1/3 stops.

Minimum power flash

← 1/128 •• 1/64 •• 1/32 •• 1/16 ••

1/8 •• 1/4 •• 1/2 •• 1/1

→ Full power flash

Flash Modes

MULTI (Multiple Flash) Mode

In Multi mode, the 170SL fires repeatedly during a single exposure, creating stroboscopic multiple-exposure effects. This operation is useful when shooting fast moving subjects. You can set the firing frequency (number of flashes per second expressed as Hz), the number of flashes, and the flash output.

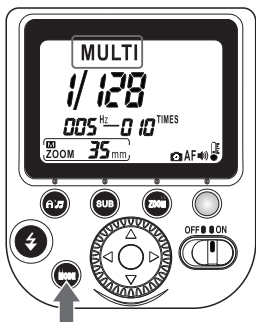

1 Set the speedlight to <MULTI>

Press the <MODE> button until <MULTI> appears on the LCD screen. Each time you press this button the 170SL will toggle among TTL, M, and MULTI modes. Watch the upper, left corner of the screen.

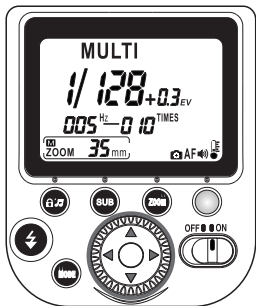

2 Set the flash output level

Press the left/right arrows on the navigation panel to decrease/increase the flash output level.

Minimum power flash

Full power flash

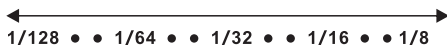

Flash Modes

MULTI (Multiple Flash) Mode

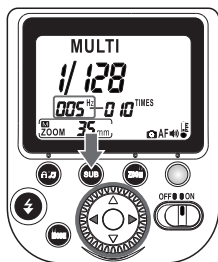

3 Set the firing frequency

- Press the <SUB> button once and the Hz number will blink.
- Press the left/right arrows on the navigation panel to decrease/increase the number. It will change by single digits between 1 and 10. It will change by 10s between 10 and 100.
- Press the <MODE> button to confirm the setting.

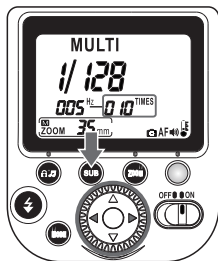

4 Set the number of flashes (times)

- Press the <SUB> button twice and the number of TIMES will blink.
- Press the left/right arrows on the navigation panel to decrease/increase the number. It will change by single digits between 1 and 10, by 5s between 10 and 50, and by 10s between 50 and 100.
- Press the <MODE> button to confirm the setting.

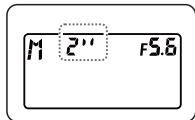

Camera shutter speed

5 Set the shutter speed

- Use the following equation to determine the shutter speed. Then set your camera to a shutter speed slower than the calculated number.
- Shutter speed = number of flashes per frame + Frequency of flash (Hz).
- For example, if the number of flashes per frame is 10 and the frequency is 5Hz, divide 10 by 5 to get a shutter speed of 2 seconds or slower (set a shutter speed of slower than 2 seconds)
- B(bulb) can be used for the shutter speed

- Using a tripod, a remote, and external power source is recommended.
- To avoid overheating and deteriorating the flash head, don't use Multi flash more than 10 times in succession. After shooting 10 times, allow a rest time of at least 15 minutes.
- The maximum flash firing number is a function of flash output level and frequency. See the appendix for more details

Wireless Modes

Master Mode (WL CTRL⁺)

■ CTRL⁺ Master Mode

With the 170SL in CTRL⁺ master mode:

- You can set the exposure compensation of the master unit to change all the slave units to be the same; but you cannot set different exposure compensation for each of the slave units.
- The Master unit will participate in the overall flash exposure.

① Set the camera's flash mode to wireless (WL)

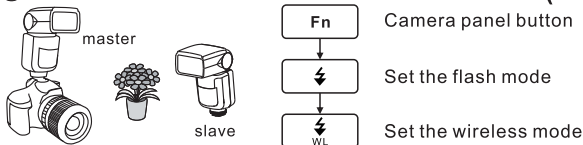

- The WL setting method may vary by camera model.
- Be sure to set the camera to wireless mode (WL) first, as you may not be able to enable the master mode of 170SL otherwise.

② Enable the CTRL⁺ master mode of 170SL

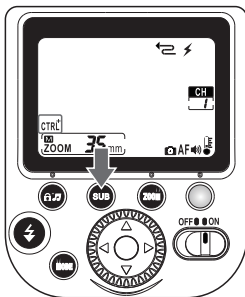

Once the camera is set to WL mode the 170SL may automatically enter it as well. If not, then press the <SUB> button for 2 seconds. Now press the <MODE> button to toggle between CTRL⁺, CTRL⁺ RATIO, and M wireless modes to reach CTRL⁺.

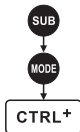

- Turning off WL via the camera may also take the 170SL out of wireless mode. If not, press the <SUB> button for 2 seconds again. *This is camera model dependent.

- As a basic guide, the effective shooting distance between the master and slave units is approx. 10M (33 ft.). The range varies slightly depending on the ambient light.
- Avoid any obstacles between the master and slave units.
- The optic sensor of slave unit s (red panel on front) should face the light source (flash head) of the master unit.
- Refer to your camera's manual for specific details about how to set it to WL mode.

Wireless Modes

Master Mode (WL CTRL⁺)

■ CTRL⁺ Master Mode

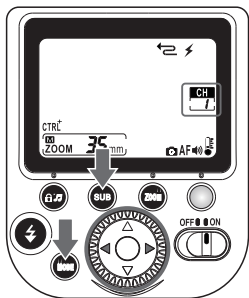

3 Set the channel

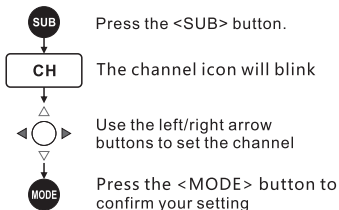

- 4 Channels are available (1,2,3,4)

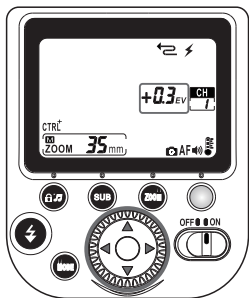

4 Set the exposure compensation amount

While in CTRL⁺ master mode (but not in channel select mode) press the left/right arrow buttons on the navigation panel to change exposure compensation by whole EV stops between -3 and +3. Use the up/down arrow buttons to change exposure compensation by 1/3 EV stops.

** Note: changing the exposure compensation in CTRL⁺ mode will change the light output of all synchronized slave units by the same amount.*

- If another photographer is using the same type of wireless flash setup nearby, your slave flash units may accidentally fire in-sync with that photographer's master flash unit. To avoid this, use a different channel number.
- The master unit and slave units should be set to the same channel number for proper operation.

Wireless Modes

Master Mode (WL CTRL⁺ RATIO)

■ CTRL⁺ RATIO Master Mode (lighting ratio control)

With the 170SL on in CTRL⁺ master mode:

- The master unit can be used to set the lighting ratio.
 - Three groups are available: the control flash itself, RMT slave group, and RMT2 slave group.
 - You can set exposure compensation from the master unit for all slave units together.
- ★ The master unit can be used in TTL mode or in M mode, but not Multi mode.

① Set the camera's flash mode to wireless (WL)

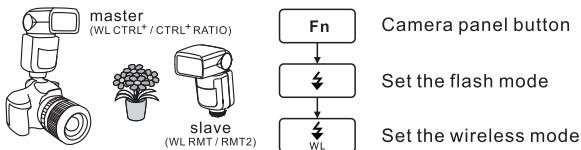

- The WL setting method may vary by camera model.
- Be sure to set the camera to wireless mode (WL) first, as you may not be able to enable the master mode of the 170SL otherwise.

② Enable the CTRL⁺ RATIO master mode of 170SL

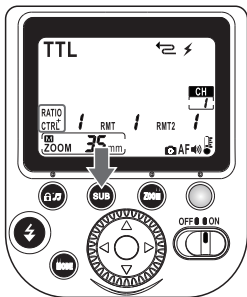

Once the camera is set to WL mode the 170SL may automatically enter it as well. If not, then press the <SUB> button for 2 seconds. Now press the <MODE> button to toggle between CTRL⁺, CTRL⁺ RATIO, and M wireless modes to reach CTRL⁺.

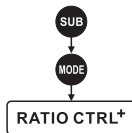

- Turning off WL via the camera may also take the 170SL out of wireless mode. If not, press the <SUB> button for 2 seconds again. *This is camera model dependent.

- As a basic guide, the effective shooting distance between the master and slave units is approx. 10M (33 f.). The range varies slightly depending on the ambient light. Don't place any obstacles between the master and slave units.
- The optic sensor of slave units (red panel on front) should face the light source (flash head) of master unit.
- Refer to your camera's manual for specific details about how to set it to WL mode.

Wireless Modes

Master Mode (WL CTRL⁺ RATIO)

■ CTRL⁺ RATIO Master Mode (lighting ratio control)

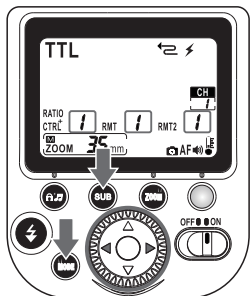

③ Set the lighting ratio values

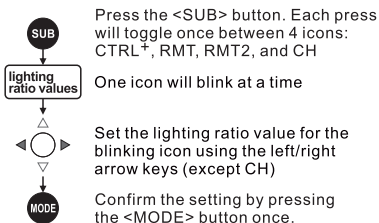

- The lighting ratio can be set in groups of up to 3.
- The range of lighting ratio values for each group is: --, 1, 2, 4, 8, and 16.

Note: A -- symbol for a group means it is shut off and will not fire.

Lighting ratio illustrated example

The values shown below are [4 : 2 : 1].

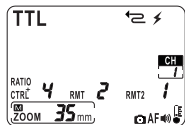

The power of these groups is 4/7, 2/7, 1/7.

The Control group or 'CTRL' group is set to 4. This group refers to the master flash itself (on camera). It will fire at 4/7 power. RMT and RMT2 are the two slave groups. You can use one or both of them. For example, you may have two slaves set to the RMT group in which case both will fire at the same power. You might have just one slave flash set to the RMT2 group, or none at all, in which case you could set RMT2 to a power of --

Wireless Modes

Master Mode (WL CTRL⁺ RATIO)

■ CTRL⁺ RATIO Master Mode (lighting ratio control)

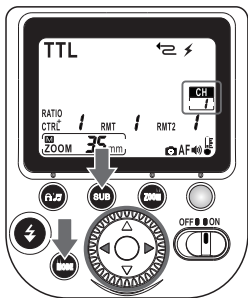

4 Set the channel

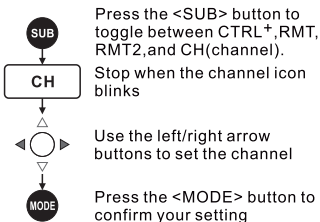

- 4 Channels are available(1.2.3.4)

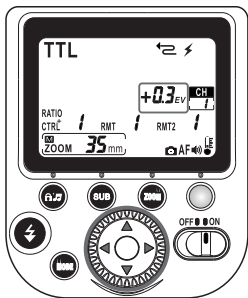

5 Set the exposure compensation amount

While in CTRL⁺ RATIO master mode (but not in ratio setting or channel select mode) press the left/right arrow buttons on the navigation panel to change exposure compensation by whole EV stops between -3 and +3.
Use the up/down arrow buttons to change exposure compensation by 1/3 EV stops.

** Note: changing the exposure compensation in CTRL⁺ RATIO mode will change the light output of all slave units by the same amount. Use the group ratios to change light output more selectively.*

- If another photographer is using the same type of wireless flash setup nearby, your slave flash units may accidentally fire in-sync with that photographer's master flash unit. To avoid this, use a different channel number.
- The master unit and slave units should be set to the same channel number for proper operation.

Wireless Modes

Slave Mode (WL TTL RMT)

TTL RMT Mode

With the 170SL in RMT slave mode:

- The 170SL can receive signals from another 170SL, Sony flash, or Sony built-in camera flash with wireless flash(WL) capability (optical pulse system only), set to CTRL+ or CTRL+ RATIO master mode.

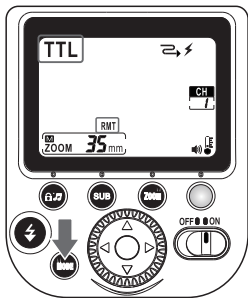

Enable TTL RMT mode

Press and hold the <MODE> button for approx. 2 seconds, until the slave icon and wireless mode icon appear in the top, right corner of the LCD screen.

Now press the <MODE> button to toggle between TTL RMT, TTL RMT2, M RMT, M RMT2, F1, and F2 slave modes to reach TTL RMT mode.

- Press and hold the <MODE> button again for approx. 2 seconds to exit slave mode.

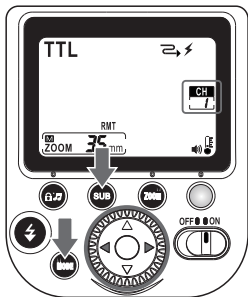

Set the channel

- Press the <SUB> button
- The channel icon will blink
- Use the left/right arrow buttons to set the channel
- Press the <MODE> button to confirm your setting

- 4 Channels are available (1,2,3,4)

- As a basic guide, the effective shooting distance between the master and slave units is approx. 10M (33 ft.). The range varies slightly depending on the ambient light. Avoid any obstacles place any obstacles between the master and slave units.
- The optic sensor of slave units (red panel on front) should face the light source (flash head) of the master unit.
- The master unit and slave units should be set to the same channel number for proper operation.

Wireless Modes

Slave Mode (WL TTL RMT 2)

TTL RMT2 Mode

With the 170SL in RMT2 slave mode:

- The 170SL can receive signals from another 170SL, Sony flash, or Sony built-in camera flash with wireless flash (WL) capability (optical pulse system only), set to CTRL⁺ RATIO master mode only (CTRL⁺ mode will not work with a slave set to RMT2).

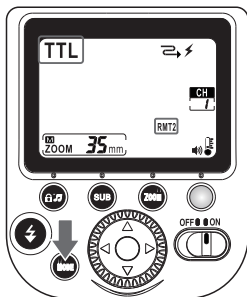

Enable TTL RMT2 mode

Press and hold the <MODE> button for approx. 2 seconds, until the slave icon and wireless mode icon appear in the top, right corner of the LCD screen.

Now press the <MODE> button to toggle between TTL RMT, TTL RMT2, M RMT, M RMT2, F1, and F2 slave modes to reach TTL RMT2 mode.

- Press and hold the <MODE> button again for approx. 2 seconds to exit slave mode.

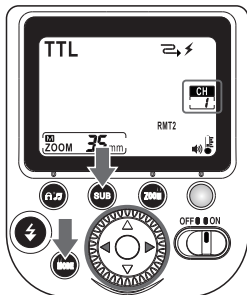

Set the channel

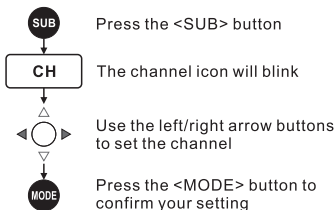

- 4 Channels are available (1, 2, 3, 4)

- The optic sensor of slave units (red panel on front) should face the light source (flash head) of the master unit.
- The master unit and slave units should be set to the same channel number for proper operation.
- TTL RMT2 mode, is only compatible with a master set to CTRL⁺ RATIO mode.

Wireless Modes

Slave Mode (WL M RMT)

M RMT Mode

With the 170SL in M RMT slave mode:

- The 170SL can receive signals from another 170SL, Sony flash, or Sony built-in camera flash with wireless flash (WL) capability (optical pulse system only) set to CTRL+ or CTRL+ RATIO mode.

Enable M RMT mode

Press and hold the <MODE> button for approx. 2 seconds, until the slave icon and wireless mode icon appear in the top, right corner of the LCD screen.

Now press the <MODE> button to toggle between TTL RMT, TTL RMT2, M RMT, M RMT2, F1, and F2 slave modes to reach M RMT mode.

- Press and hold the <MODE> button again for approx. 2 seconds to exit slave mode.

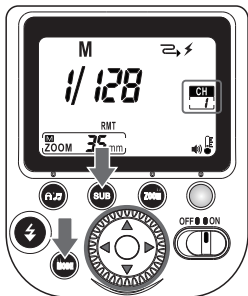
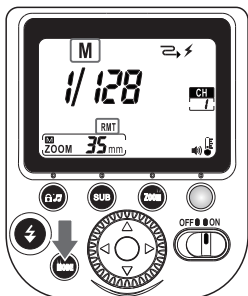

Set the channel

- Press the <SUB> button
- The channel icon will blink
- Use the left/right arrow buttons to set the channel
- Press the <MODE> button to confirm your setting

- 4 Channels are available (1, 2, 3, 4)

Set the flash power

- Press the up/down arrow buttons to change the power by 1/3 EV stops.
- Press the left/right arrow buttons to change the power by whole EV stops

- When a slave unit is in M RMT mode, the master unit can't control the slave unit's flash power. Set the flash power directly on the slave unit(s).
- The master unit and slave units should be set to the same channel number for proper operation.

Wireless Modes

Slave Mode (WL M RMT2)

M RMT2 Mode

With the 170SL in M RMT2 slave mode:

- The 170SL can receive signals from another 170SL, Sony flash, or Sony builtin camera flash with wireless flash (WL) capability (optical pulse system only), set to CTRL+ RATIO master mode only (CTRL+ mode will not work with a slave set to M RMT2).

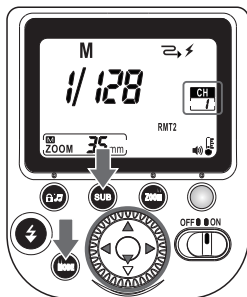
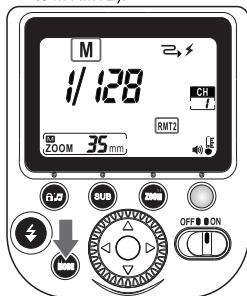

Enable M RMT2 mode

Press and hold the <MODE> button for approx. 2 seconds, until the slave icon and wireless mode icon appear in the top, right corner of the LCD screen.

Now press the <MODE> button to toggle between TTL RMT, TTL RMT2, M RMT, M RMT2, F1 and F2 slave modes to reach M RMT2 mode.

- Press and hold the <MODE> button again for approx. 2 seconds to exit slave mode.

Set the channel

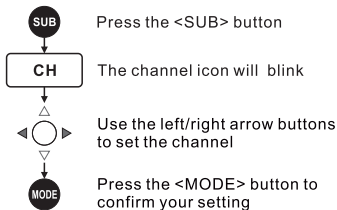

- 4 Channels are available (1, 2, 3, 4)

Set the flash power

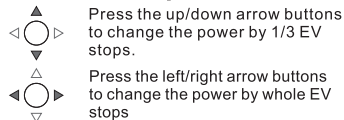

- When a slave unit is in M RMT2 mode, the master unit can't control the slave unit's flash power. Set the flash power directly on the slave units.
- The master unit and slave units should be set to the same channel number for proper operation.
- TTL M RMT2 mode is only compatible with a master set to CTRL+ RATIO mode.

Wireless Modes

Slave Mode F1 (Optical)

The F1 slave mode is used in a manual flash environment. It is particularly useful when using a non Sony-compatible master flash manually (non-TTL).



Enable F1 mode

Press and hold the <MODE> button for approx. 2 seconds, until the slave icon and wireless mode icon appear in the top, right corner of the LCD screen.

Now press the <MODE> button to toggle between TTL RMT, TTL RMT2, M RMT, M RMT2, F1, and F2 slave modes to reach F1 mode.

- Press and hold the <MODE> button again for approx. 2 seconds to exit slave mode.



Set the flash power



Press the up/down arrow buttons to change the power by 1/3 EV stops.



Press the left/right arrow buttons to change the power by whole EV stops

- When the speedlight is in F1 slave mode, it will fire in-sync. with the master flash, similar to a radio slave setup. To use this mode correctly, the master speedlight should be set as a manual flash and the TIL flash system with pre-flash and red-eye reduction modes should not be used.
- As a basic guide, the effective shooting distance between the master and slave units is approx. 10M (33 ft.). The range varies slightly depending on the ambient light. Avoid any obstacles between the master and slave units.
- The optic sensor of slave units (red panel on front) should face the light source (flash head) of the master unit.

Wireless Modes

Slave Mode F2 (Optical)

The F2 slave mode is used in a TTL flash environment so as to ignore preflashes and properly fire in-sync with the master. The F2 slave operates only as a manual unit. It is particularly useful when using a non Sony-compatible master flash in TTL.

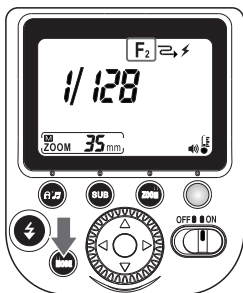

Enable F2 mode

Press and hold the <MODE> button for approx. 2 seconds, until the slave icon and wireless mode icon appear in the top, right corner of the LCD screen.

Now press the <MODE> button to toggle between TTL RMT, TTL RMT2, M RMT, M RMT2, F1, and F2 slave sub modes to reach F2 mode.

- Press and hold the <MODE> button again for approx. 2 seconds to exit slave mode.

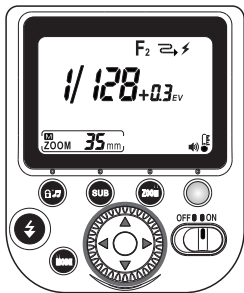

Set the flash power

Press the up/down arrow buttons to change the power by 1/3 EV stops.

Press the left/right arrow buttons to change the power by whole EV stops

- When the slave speedlight is in F2 mode it can sync with the master speedlight in its TTL mode although the slave will function manually.
- As a basic guide, the effective shooting distance between the master and slave units is approx. 10M (33 f.). The range varies slightly depending on the ambient light. Avoid any obstacles between the master and slave units.
- The optic sensor of slave units (red panel on front) should to face the light source (flash head) of the master unit.

Wireless Modes

Using the Camera's Built-in Flash as a Master (CTRL⁺)

Some Sony SLT series cameras can use their own, built-in flash as a wireless commander. When using a camera with this capability, follow the instructions below to set the 170SL as a slave.

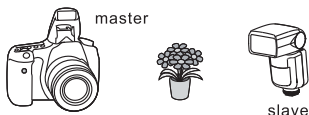

1. Attach the 170SL to the camera and turn the power of both the 170SL and camera on.
2. Set the camera's flash mode to wireless (WL) using its menu controls.
 - The method for setting wireless differs depending on the camera used. For details, refer to the operating instructions of your camera.
 - Once the camera is set to wireless flash, the 170SL will also change automatically to wireless and will display CTRL⁺ on its screen.
 - The flash channel information is transmitted to the camera. (You may use the flash unit to change the camera channel.)
3. Remove the flash unit from the camera and raise the built-in flash.
4. Change the 170SL to [WL TTL RMT] or [WL TTL RMT2] mode as a slave unit.
 - The slave unit can also be set to [WL M RMT] or [WL M RMT2] allowing you to manually adjust the power level (non TTL).
5. Test the setup.

The AF illuminator on the front of the 170SL will blink to show it is in slave mode. Take some test shots to ensure the 170SL is firing remotely and you are getting exposures you expect.

Note: If the test fails you may start over and reattach the 170SL to your camera to re-synchronize their wireless connection. If it continues to fail you may have a non-compatible camera. Check the camera's setting to see if it remains in WL mode once the 170SL is removed. If the camera does not remain in WL mode and/or will not allow you to access WL mode when the 170SL is removed but the built-in flash is popped-up, it is an indication the camera does not support this feature. In this instance you may get a warning message on the camera's LCD screen that reads " ! Invalid with this flash."

Advanced Applications

Power Zoom Function

The power zoom function automatically adjusts the flash zoom head position to match the lens focal length. Zoom positions can be adjusted between 24mm and 180mm. You can also adjust the flash zoom head position manually.

A= Automatic(The flash zoom in sync with camera lens)

M= Manual zoom

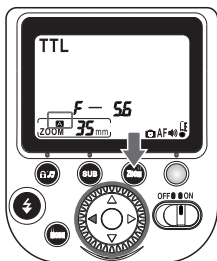

Setting auto zoom

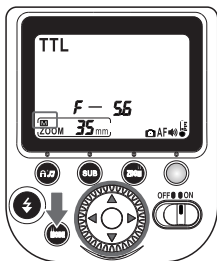
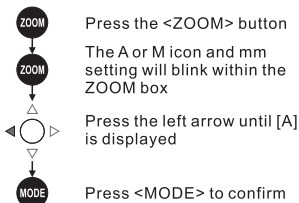

Setting manual zoom

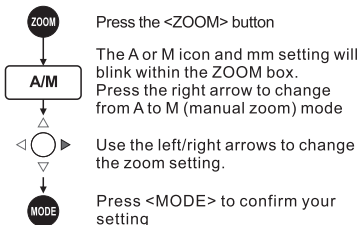

The zooming adjustable range(mm),
--, 24, 28, 35, 50, 70, 105, 135, 180
↑
Auto zoom (Off communication state)

- If you set the flash zoom manually, make sure it covers the lens focal length so that the picture will not have a dark periphery (the appearance of vignetting on the edges of the photo).
- The flash zoom range is 24-180mm, if the lens focal is longer than 180mm, it will display 180mm, if lens focal shorter than 24mm, it will display 24mm.
- If you are using a sync cord to connect the camera to the speedlight's PC terminal, be sure to set the flash zoom manually since the auto zoom will not work.

Advanced Applications

AF Assist Beam Emitter (AF)

In low light conditions the AF assist light will automatically emit a red colored beam and illuminate the subject so the camera can easily focus. The 170SL AF assist beam is enable by default. You can disable it through the camera's menu.

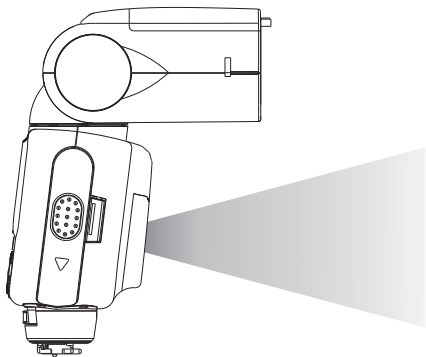

- When the 170SL is in slave mode, the AF light will blink as a way of showing it is an active slave.

Advanced Applications

Bounce Flash Operation

Tilt or rotate the 170SL's flash head to bounce the light off a ceiling or walls, providing more natural-looking pictures of people with softer shadows.

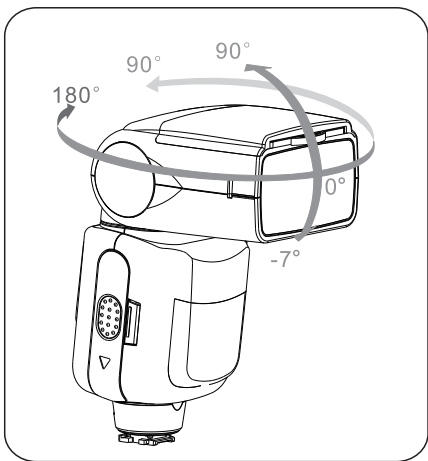

Vertical angle adjustment: -7° -- 0° -- 45° -- 60° -- 75° -- 90°

Rotation adjustment: Left: 0° -- 30° -- 60° -- 90°)

Right: 0° -- 30° -- 60° -- 90° -- 120° -- 135° -- 180°

- If the wall or ceiling is too far away, the bounced flash might be too weak and result in under exposure.
- Be sure to select a white/neutral surface to bounce the light off of. Otherwise your pictures will have an unnatural looking color cast similar to that of the reflecting surface.

Advanced Applications Using the Bounce Card

You can use the 170SL's built-in bounce card to create a highlight in the subject's eyes, soften the light output, and reduce the chance of red-eye (by creating more distance between the light and the lens).

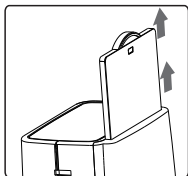
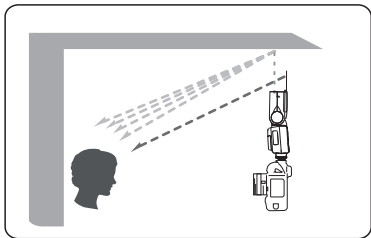

1 Point the flash head upward by 90°.

2 Pull out the wide panel.

The bounce card panel will come out at the same time.

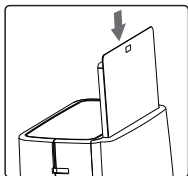

3 Push the wide panel back in.

Push in only the wide panel. Leave the bounce card out.

- Point the flash head straight ahead and then upward by 90°. The bounce card will not work properly if you swing the flash head left or right.
- For maximum effect, stay within 1.5m (4.9ft) of the subject.

Advanced Applications Using the Wide Panel

When the distance between the camera and subject is less than approximately 2m (6 1/2 ft), you can take more natural-looking close-up pictures using the wide panel. The wide panel also widens the flash beam to cover an 18mm zoom position.

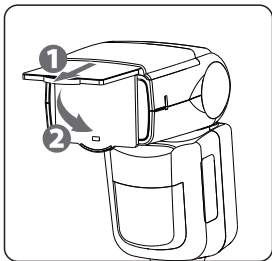

❶ Pull out the wide panel.

Slowly pull out the wide panel all the way, and position it over the flash head.

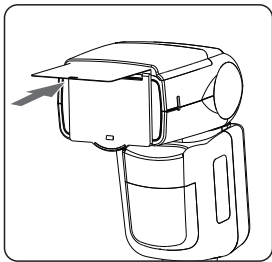

❷ Push the bounce card back in.

Push in only the bounce card. Leave the wide panel out.

- The wide panel is most effective when the 170SL's zoom head reflector is set to its widest-angle position. To accomplish this you can either set your zoom lens to its widest position while the 170SL is in auto zoom mode, or you can switch to manual zoom mode and change the 170SL's zoom position to its widest setting.

Additional Interfaces

The 170SL has external connections for use of an external power source (High Voltage battery pack) or PC sync.

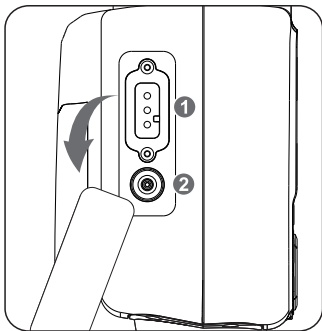

1 Accessing the external power connector and PC sync.

Use the thumb tab to pull open the rubber cover on the side of the 170SL and rotate it out of the way.

2 Connecting.

1. PC Sync terminal: The Speedlight can fire in sync. using this socket.
2. External power connector: The H.V. (high voltage) port provides a stable power supply.

- External power source: Use of an optional, external power source connected to the 170SL's H.V. port provides a stable power supply and increases the number of flash firings while shortening shot-to-shot recycling times.
- PC Sync terminal: By connecting to the PC terminal you can fire the flash manually from a camera's PC terminal socket (using the proper cord). The PC terminal ONLY fires the flash and does not support TTL or any other automatic, or exposure features.

Appendix

Maximum number of MULTI flashes per frame

Frequency	Flash output level				
	M1/8	M1/16	M1/32	M1/64	M1/128
1Hz	100	100	100	100	100
2Hz	100	100	100	100	100
3Hz	100	100	100	100	100
4Hz	15	100	100	100	100
5Hz	10	100	100	100	100
6Hz	10	100	100	100	100
7Hz	7	40	100	100	100
8Hz	7	35	100	100	100
9Hz	7	20	100	100	100
10Hz	7	20	100	100	100
20Hz	5	10	25	100	100
30Hz	5	10	20	60	100
40Hz	5	10	20	45	100
50Hz	4	9	18	40	100
60Hz	4	9	18	32	100
70Hz	4	9	17	32	100
80Hz	4	8	17	32	100
90Hz	4	8	17	30	60
100Hz	4	8	17	30	60

Guide No. (ISO 100, in meters)

Flash output level	Zoom position(mm)							
	24	28	35	50	70	105	135	180
1/1	25.4	27.9	31.4	35.8	39.3	44.4	48.4	52.0
1/2	18.0	19.7	22.2	25.3	27.8	31.4	34.2	35.4
1/4	12.7	14.0	15.7	17.9	19.7	22.2	24.2	25.0
1/8	9.0	9.9	11.1	12.7	13.9	15.7	17.1	17.7
1/16	6.4	7.0	7.9	9.0	9.9	11.1	12.1	12.5
1/32	4.5	5.0	5.6	6.4	7.0	7.9	8.6	8.9
1/64	3.2	3.5	4.0	4.5	5.0	5.6	6.1	6.3
1/128	2.3	2.5	2.8	3.2	3.5	4.0	4.3	4.5

Specifications

Type	On-camera, TTL/ADI speedlight
Guide No.	Approx. GN52/ 170' (@ 180mm focal length, ISO100)
Flash coverage	24 to 180mm (18mm when using wide panel) ● Manual zoom ● Automatic
Bounce angle	90°Up, 7°Down, 90°Left, 180°Right
Flash modes	TTL/M/MULTI & Wireless modes
Audible	Electronic beep (ON or OFF)
Wireless mode	Sony CTRL+ and CTRL+ RATIO master modes; TTL RMT, TTL RMT2, M RMT, and M RMT2 slave modes F1 and F2 manual modes
Display type	LCD display with LED backlight
Color temperature	5600K
Flash exposure compensation	3.0 EV to +3.0 EV in increments of 1/3 EV steps
Manual Flash Control	22 Levels of light output control (1/1 - 1/128)
Power supply	4 X AA size batteries (Alkaline or NiMH cells)
Recycle time	0.2-4.5 seconds (AA alkaline cell use) 0.1-2.5 seconds (AA NiMH cell use)
Power saving	Support on-camera mode (auto standby after 3 minutes of non use)
Repeating Flash	1-100Hz (on-camera)
Flash duration range	1/800~1/20000 sec.
Camera's sync modes	Front-curtain sync, Rear-curtain sync
AE lock (AE)	Support
External power	Support via H.V. port
PC terminal	Support
Dimensions	7 3/4" × 3 1/16" × 2 5/16 (196.8mm×77.8mm×58.7mm)
Weight	Approx. 396 g / 14 oz. (without batteries)

